

DSB05

Load cells 称重传感器

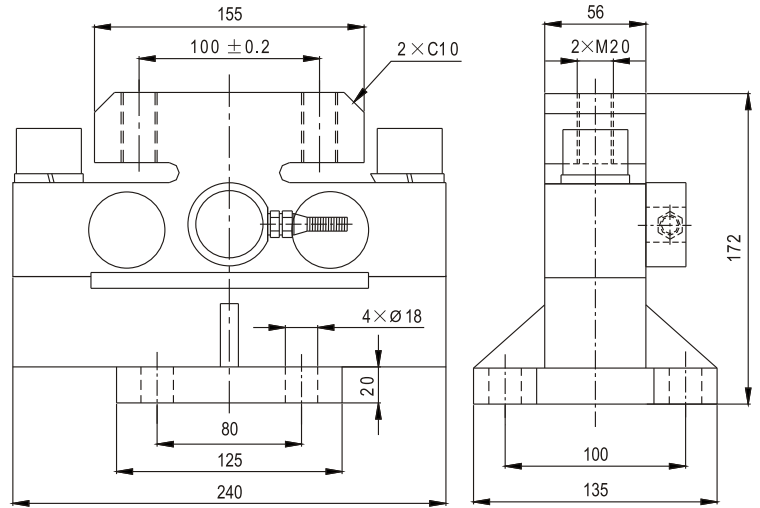
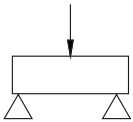
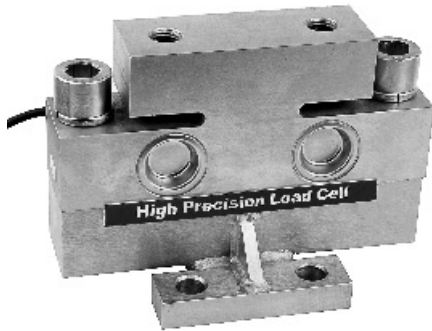

钢包秤, 罐装秤及各种起重机械
Steel embody, canned scale, every kinds of crane mechanism

Specifications 技术说明 Exc+激励正 (Red,红);Exc-激励负(Black,黑);Sig+信号正(Green,绿);Sig-信号负(White,白)

Item 项目	Unit 单位	Parameter 参数
Accuracy class to OIML R 60 精度等级		C1
Maximum capacity (E_{max}) 额定载荷	t	10,15,20,30,40
Minimum LC verification interval (V _{min}) 最小检定分度值	% of E _{max}	0.0500
Sensitivity (C_n) / Zero balance 灵敏度/零点平衡	mV/V	2.0 ± 0.002 / 0 ± 0.02
Temperature effect on zero balance (TK ₀) 温度对零点影响	% of C _n /10K	±0.02
Temperature effect on sensitivity (TK _c) 温度对灵敏度影响	% of C _n /10K	±0.02
Hysteresis error (d _{hy}) 滞后误差	% of C _n	±0.1000
Non-linearity(d _{lin}) 非线性误差	% of C _n	±0.1000
Creep(d _{cr}) over 30 min. 蠕变及蠕变恢复	% of C _n	±0.030
Input (R_{LC}) & Output resistance (R_o) 输入&输出电阻	Ω	750 ± 10 & 703 ± 2
Nominal range of excitation voltage (B_u) 额定电压	V	5~12
Insulation resistance (R _{is}) at 50Vdc 绝缘电阻	MΩ	≥5000
Service temperature range (B _{tu}) 工作温度	°C	-30...+70
Safe load limit (E _L) & Breaking load (E _d) 安全承载&破坏载荷	% of E _{max}	150 & 300
Protection class according to EN 605 29 (IEC 529) 保护等级		IP68
Material :Measuring element 材料: 弹性体 Cable fitting 电缆配件/Cable-sheath 电缆护套		Alloy steel Nickel-plated brass/PVC

Maximum capacity (E _{max}) 额定载荷	t	10	15	20	30	40
Deflection at E _{max} (s _{nom}), approx 最大载荷下的变形量	mm	0.65			0.55	
Weight(G), approx 重量	kg	15.3				
Cable 电缆: Diameter 直径: Ø6mm Length 长度	m	8	12		14	