

DSB07

Load cells 称重传感器

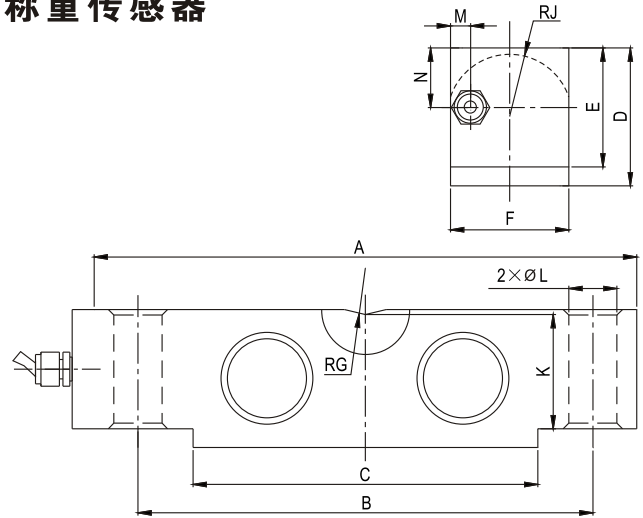
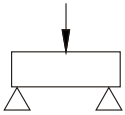
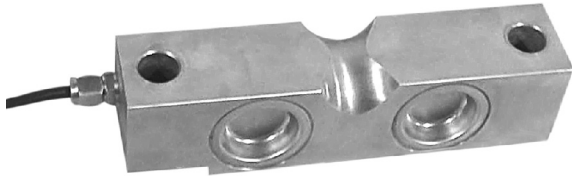

汽车衡、仓储秤等
Truck scale, axle wheel scale, warehouse scale

Emax[klb]	A	B	C	D	E	F	G	J	K	L	M	N
10~25	196.9	165.1	125.1	49.3	43.2	42.9	19.1	22.9	41.4	17.3	8.8	13.6
40	260.4	215.9	162.4	62.0	53.3	49.3	25.4	28.5	50.8	20.6	9.0	31.0
50~75	260.4	215.9	162.4	74.7	67.3	62.0	25.4	34.8	64.5	27.0	10.0	37.4

Specifications 技术说明 Exc+激励正 (Red,红);Exc-激励负(Black,黑);Sig+信号正(Green,绿);Sig-信号负(White,白)

Item 项目	Unit 单位	Parameter 参数	
Accuracy class to OIML R 60 精度等级		D1	C2
Maximum capacity (Emax) 额定载荷	klb	10,20,25,40,50,60,75	
Minimum LC verification interval (Vmin) 最小检定分度值	% of Emax	0.0200	0.0100
Sensitivity (Cn) / Zero balance 灵敏度/零点平衡	mV/V	3.0 ± 0.003 / 0 ± 0.03	
Temperature effect on zero balance (TK0) 温度对零点影响	% of Cn/10K	±0.0252	±0.02
Temperature effect on sensitivity (TKc) 温度对灵敏度影响	% of Cn/10K	±0.0252	±0.02
Hysteresis error (dhy) 滞后误差	% of Cn	±0.0500	±0.0270
Non-linearity(dlin) 非线性误差	% of Cn	±0.0500	±0.0250
Creep(dcr) over 30 min. 蠕变及蠕变恢复	% of Cn	±0.033	±0.030
Input (RLc) & Output resistance (Ro) 输入&输出电阻	Ω	750 ± 10 & 703 ± 2	
Nominal range of excitation voltage (Bu) 额定电压	V	5~12	
Insulation resistance (Ris) at 50Vdc 绝缘电阻	MΩ	≥5000	
Service temperature range (Btu) 工作温度	°C	-30...+70	
Safe load limit (EL) & Breaking load(Ed) 安全承载&破坏载荷	% of Emax	150 & 250	
Protection class according to EN 60 529 (IEC 529) 保护等级		IP68	
Material :Measuring element 材料: 弹性体 Cable fitting 电缆配件/Cable-sheath 电缆护套		Alloy steel or stainless steel Nickel-plated brass/PVC	

Maximum capacity (Emax) 额定载荷	klb	10	20	25	40	50	60	75
Deflection at Emax (snom) ,approx最大载荷下的变形量	mm	0.65		0.75		0.85		
Weight(G),approx 重量	kg	2.9		5.3		7.8		
Cable 电缆: Diameter 直径: Ø6mm Length长度	m	12		12		16		