

BL01/M01

Weighing module for 50kg...500kg 用于50kg到500kg的称重模块

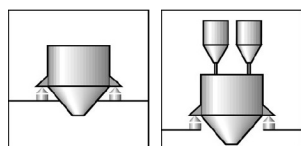
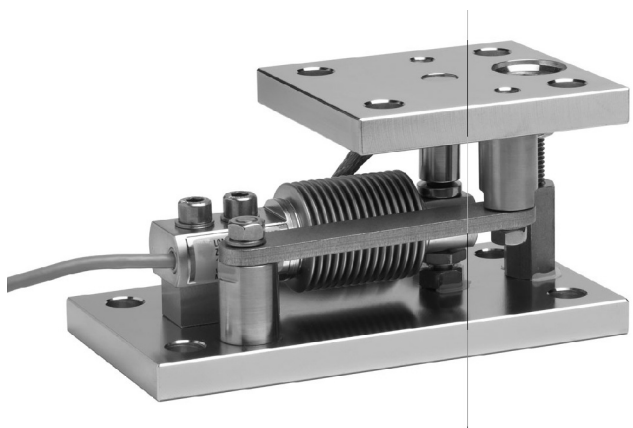

Special features 特点

- Equipped with load cell BL01,
- class C2,C3 according to OIML R60
- With overload stop and stay rod
- Compact installation at minimum installation height
- Easy installation
- Two versions available: Galvanized or stainless steel
- Self-restoring due to pendulum bearing
- With anti-liftoff device and lifting device
- 用于精度等级为C2, C3的BL01传感器
- 有过载保护与支撑杆
- 结构紧凑
- 安装简单
- 电镀材料与不锈钢材料可选
- 采取摆支撑有自复位功能
- 带有升力与反升力装置

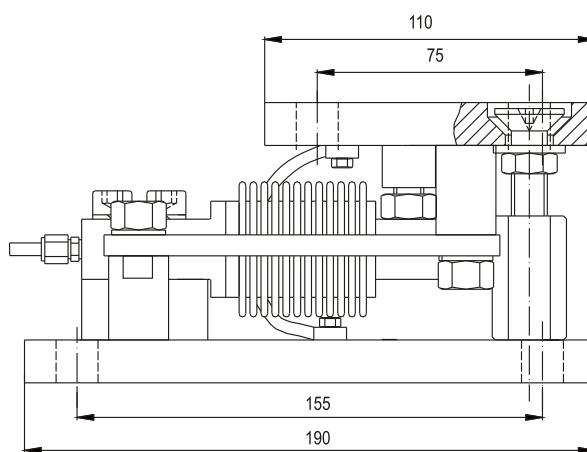
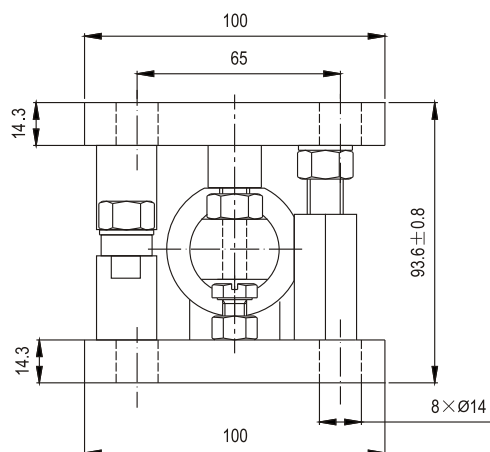

Specifications 技术说明 Exc+激励正 (Red,红);Exc-激励负(Black,黑);Sig+信号正(Green,绿);Sig-信号负(White,白)

Maximum capacity 额定载荷	kg	50	75	100	200	250	300	500
Limit load 安全载荷	% of Emax	120%						
Breaking load 破坏载荷	% of Emax	200%						
Total error of load cells 传感器综合性能	% of Emax	±0.02, ±0.03, ±0.05						
Material 材料:		Galvanized or stainless steel 电镀材料或不锈钢						
Weight (incl.load cell) 重量	kg	8..9						
Adjustment range of the overload stop 过载保护范围	mm	≤0.33	≤0.25	≤0.45	≤0.8			
Cable 电缆: Diameter直径 ∅6mm Length长度	m	3						