

PC03/M01

Weighing module for 10t...50t 用于10t到50t的称重模块

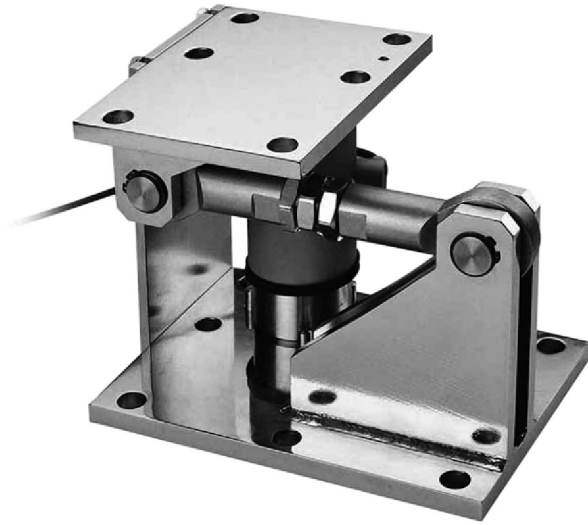

Special features 特点

- Equipped with self-restoring rocker pin load cell PC01, class C2,C3 according to OIML R60
- Compact installation at minimum installation height
- Easy installation
- Limit load is 200%
- Two versions available:
Galvanized material Stainless steel
- 用于精度等级为C2, C3的自复位柱式传感器PC02
- 结构紧凑
- 安装简单
- 安全过载能力强
- 电镀材料和不锈钢可选

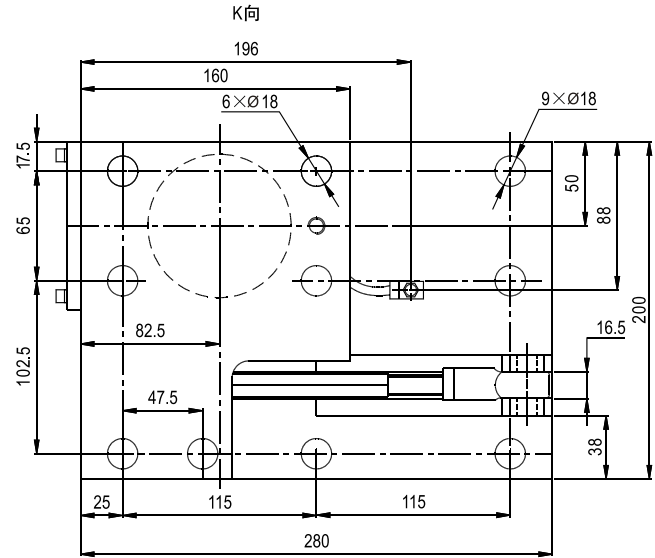
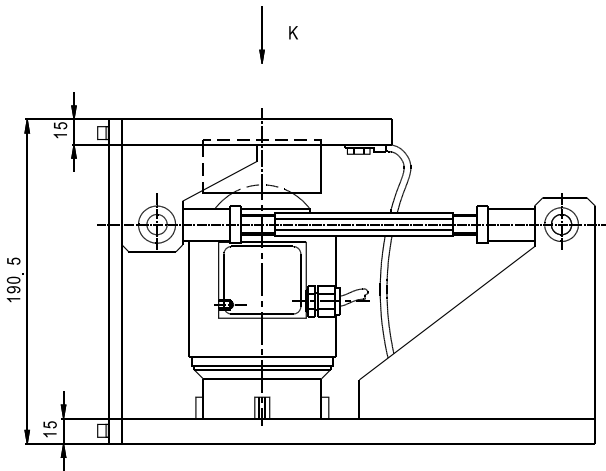

Specifications 技术说明 Exc+激励正 (Red,红);Exc-激励负(Black,黑);Sig+信号正(Green,绿);Sig-信号负(White,白)

Maximum capacity 额定载荷	t	10	20	25	30	40	50
Limit load 安全载荷	% of Maximum capacity	150%					
Restoring force (at 1mm side offset 回复力 vertically to the control arm direction)	% of Applied load	0.35	0.38	0.45	0.56	0.64	0.64
Maximum permissible side offset transverse to the control arm axis 控制臂方向最大允许水平位移	mm	3.0					
Maximum permissible horizontal force in the control arm direction 控制臂方向最大允许水平力	kN	50					
Material 材料:		Galvanized or stainless steel 电镀材料或不锈钢					
Weight(G),approx. 重量	kg	17.5					
Cable 电缆: Diameter 直径 \varnothing 6mm Length 长度	m	10	12	14	16		

Mounting examples for weighing modules with stay rods: 带有支撑杆的称重模块安装示例

Cylindrical arrangement of the weighing module below tanks
 称重模块在罐下部的圆形布置

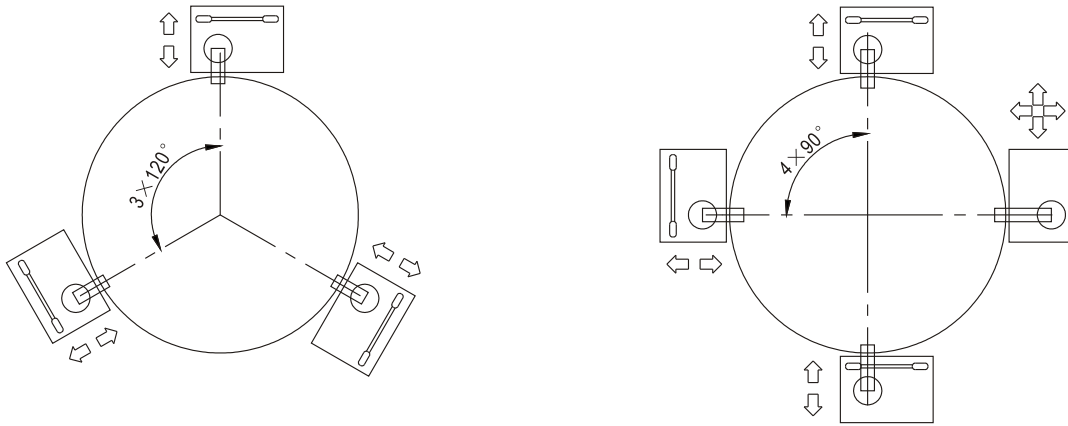

Rectangular arrangement of the weighing module below tanks
 称重模块在罐下部的方形布置

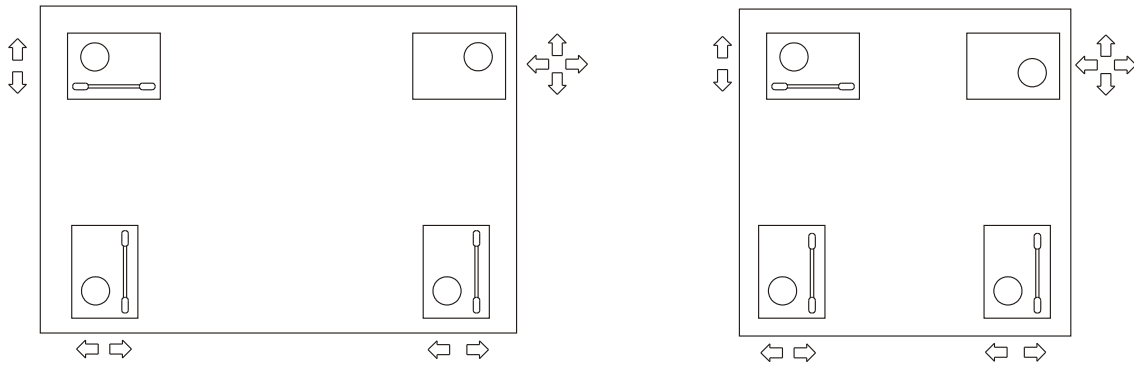

Remark 备注: Stay rod 支撑杆 Load introduction 负载方向 Degree of freedom 自由度

Further accessory: 其他附件

Fixed bearings with the same installation height as the weighing module.
 PC03/M01可提供此种对应安装尺寸附件。

