

# SSB01/M01

Static weighing module for 500kg...25t  
用于500kg到25t的静载称重模块



## Special features 特点

- Equipped with load cell SSB01, class C2,C3 according to OIML R60
- Compact installation at minimum installation height
- Easy installation
- Two versions available: Galvanized material, Stainless steel
- With anti-liftoff device and lifting device
- 用于精度等级为C2, C3的SSB01形传感器;
- 结构紧凑
- 安装简单
- 电镀材料和不锈钢可选
- 带有升力与反升力装置

Dimensions (in mm; 1mm=0.03937 inches) 尺寸

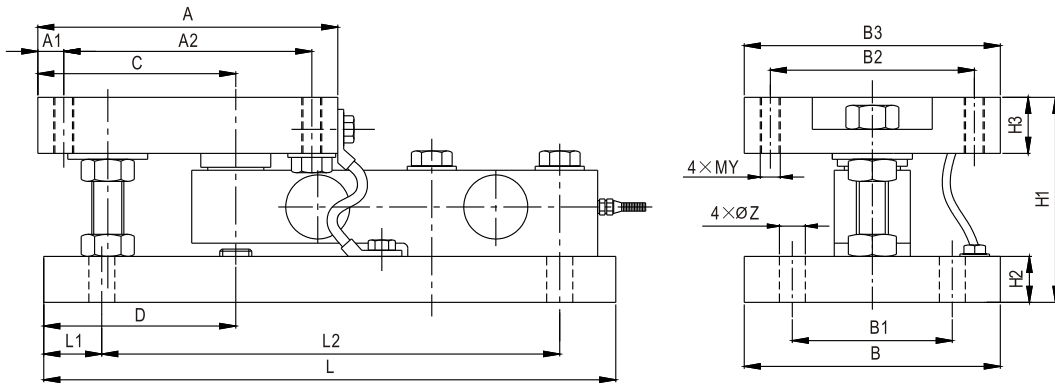

Emax [t]	A	A1	A2	C	D	L	L1	L2	B	B1	B2	B3	H1	H2	H3	Y	Z
0.5, 1, 2, 3	150	16	124	99	96	286	32	226	112	80	102	128	102	23	28	10	13
5, 8	178	16	146	102	99	318	32	257	152	102	120	152	130	30	38	16	17
10, 15	184	16	152	108	105	360	32	295	154	106	122	154	168	45	45	20	21
20, 25	220	25	170	115	115	400	25	350	220	170	170	220	213	55	55	24	26

Specifications 技术说明 Exc+激励正 (Red, 红); Exc-激励负 (Black, 黑); Sig+信号正 (Green, 绿); Sig-信号负 (White, 白)

Maximum capacity 额定载荷	t	0.5	1	2	3	5	8	10	15	20	25
Limit load 安全载荷	% of Emax	150%									
Total error of load cells 传感器综合性能	% of Emax	±0.02, ±0.03, ±0.05									
Material 材料:		Galvanized or stainless steel 电镀材料或不锈钢									
Cable 电缆: Diameter 直径 Ø6mm Length 长度	m	2.6	3.5	5.2	5.2	7	12	12	12		

Mounting examples for weighing modules 安装方式

