

SSB01/M02

Dynamic weighing module for 500kg...25t
用于500kg到25t的动载称重模块

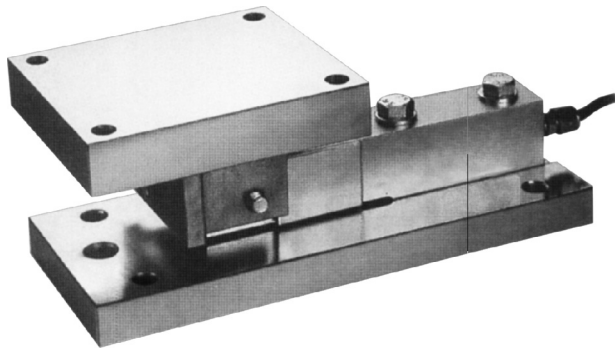

Special features 特点

- Equipped with self-restoring load cell SSB01, class C2,C3 according to OIML R60
- Compact installation at minimum installation height
- Easy installation
- Two versions available:
Galvanized material
Stainless steel
- 用于精度等级为C2, C3的不倒翁自复位传感器SSB01
- 结构紧凑
- 安装简便
- 电镀材料和不锈钢可选

Dimensions (in mm; 1mm=0.03937 inches) 尺寸

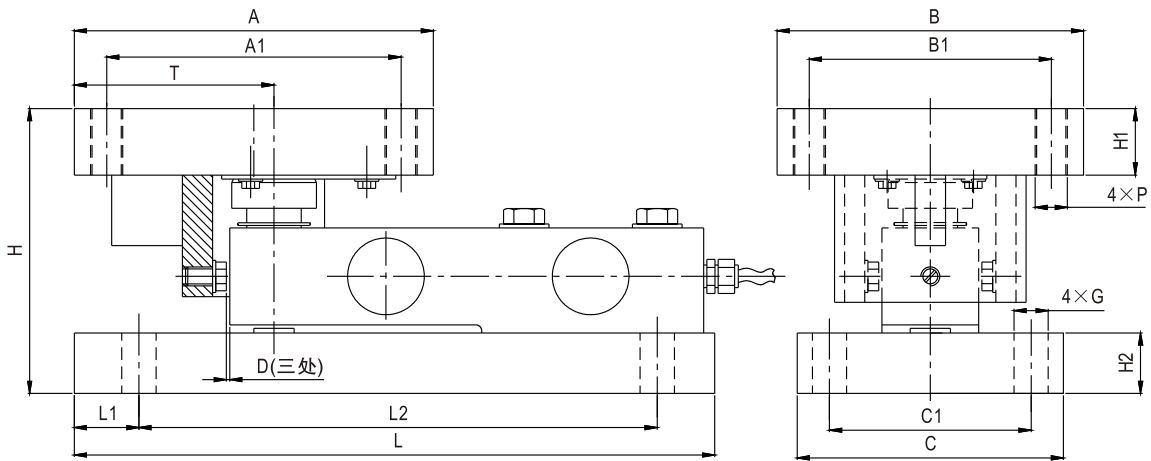

Emax [t]	A	A1	B	B1	T	L	L1	L2	C	C1	H	H1	H2	P	G	D
0.5,1,2,3	150	124	128	102	96	286	32	226	112	80	102	28	23	M10	ø13	1.6
5,8	178	146	152	120	99	318	32	257	152	102	130	38	30	M16	ø17	1.6
10,15	184	152	154	122	105	360	32	295	154	106	168	45	45	M20	ø21	3
20,25	220	170	220	170	115	400	25	350	220	170	213	55	55	M24	ø26	3

Specifications 技术说明 Exc+激励正 (Red,红);Exc-激励负(Black,黑);Sig+信号正(Green,绿);Sig-信号负(White,白)

Maximum capacity 额定载荷	t	0.5	1	2	3	5	8	10	15	20	25
Limit load 安全载荷	% of Emax	150%									
Total error of load cells 传感器综合性能	% of Emax	±0.02, ±0.03, ±0.05									
Material 材料:		Galvanized or stainless steel 电镀材料或不锈钢									
Cable 电缆: Diameter直径 ø6mm Length长度	m	2.6	3.5	5.2	7	12					

Mounting examples for weighing modules 安装方式

Cutting install 切向方式

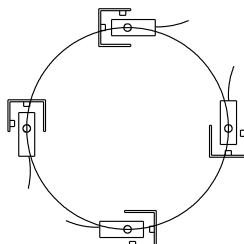

Rectangle Install 矩形方式

